



(19) **United States**

(12) **Patent Application Publication**

Li et al.

(10) **Pub. No.: US 2004/0150613 A1**

(43) **Pub. Date:**

**Aug. 5, 2004**

(54) **PHOTOLUMINESCENT ELECTROPHORETIC DISPLAY**

(57) **ABSTRACT**

(76) Inventors: **Zili Li**, Barrington, IL (US); **Zane Coleman**, Chicago, IL (US)

Correspondence Address:  
**MOTOROLA, INC.**  
**1303 EAST ALGONQUIN ROAD**  
**IL01/3RD**  
**SCHAUMBURG, IL 60196**

(21) Appl. No.: **10/356,003**

(22) Filed: **Jan. 31, 2003**

**Publication Classification**

(51) **Int. Cl.<sup>7</sup>** ..... **G09G 3/34**

(52) **U.S. Cl.** ..... **345/107**

Electrophoretic displays (**100, 400**) comprise suspensions in one or more bodies of liquid (**116, 418, 426**) of reflective particles (**118, 420**), and photoluminescent particles (**120, 422**). The one or more bodies of liquid are located between a front wall (**104, 402**) and a back wall (**102, 404**). Electrodes (**128, 129, 410, 412**) and optionally a transparent ground plane layer (**124**) are provided for applying electric fields to the suspensions according to image information. The reflective particles and the photoluminescent particles are characterized by the electrophoretic mobilities of the same sign, and therefore move in the same direction in response to applied fields. A source of radiation (**140, 428**) capable of exciting photoluminescence of the photoluminescent particles is optically coupled to the liquid suspensions. An optical filter layer is optionally located at the front of the displays. The display is capable of operating under a wide range of ambient light conditions.

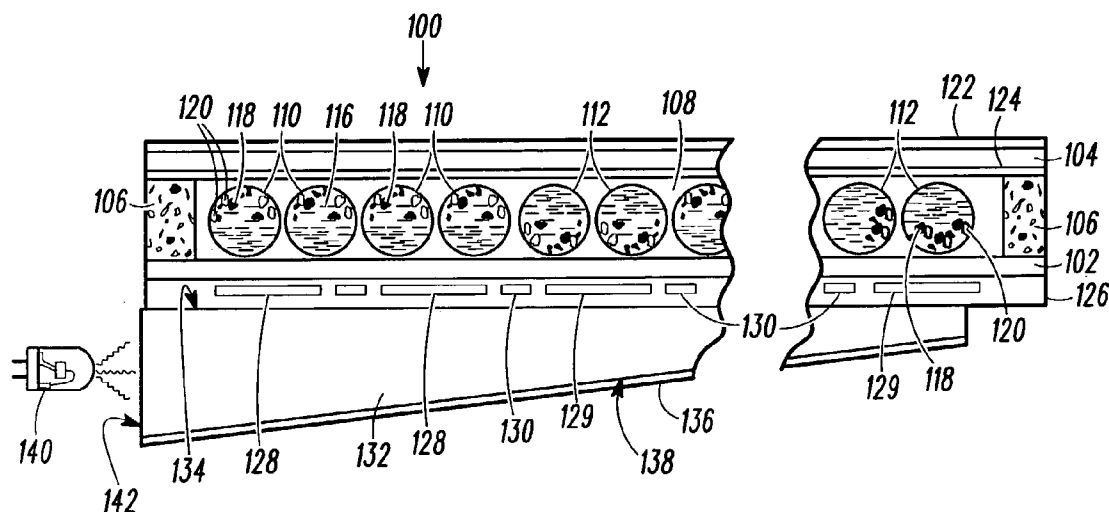

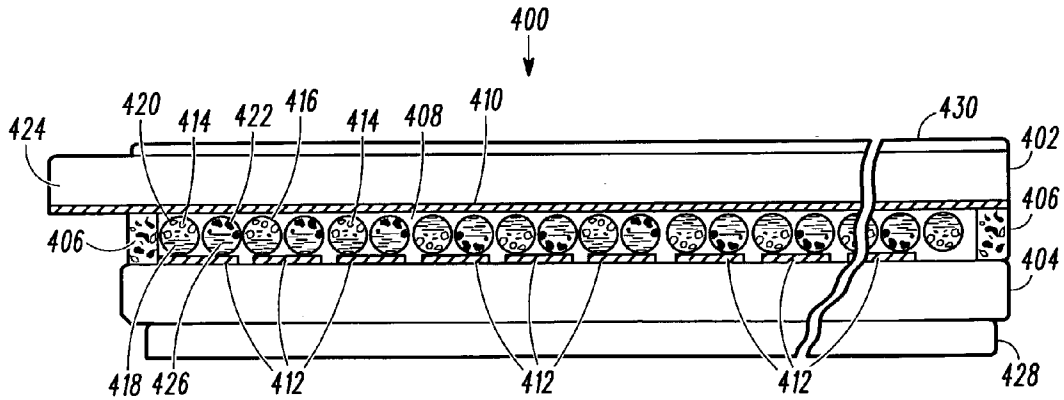
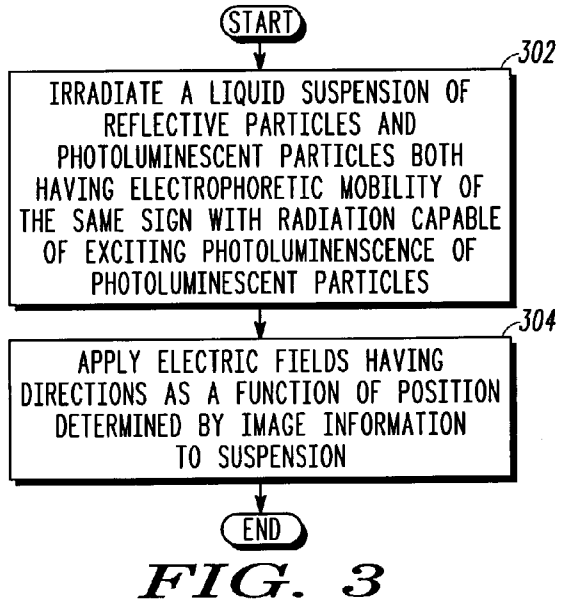
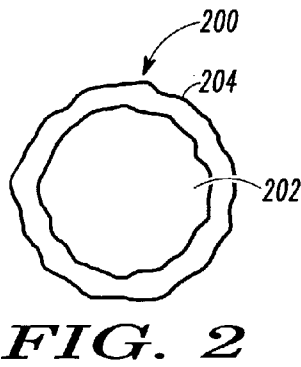
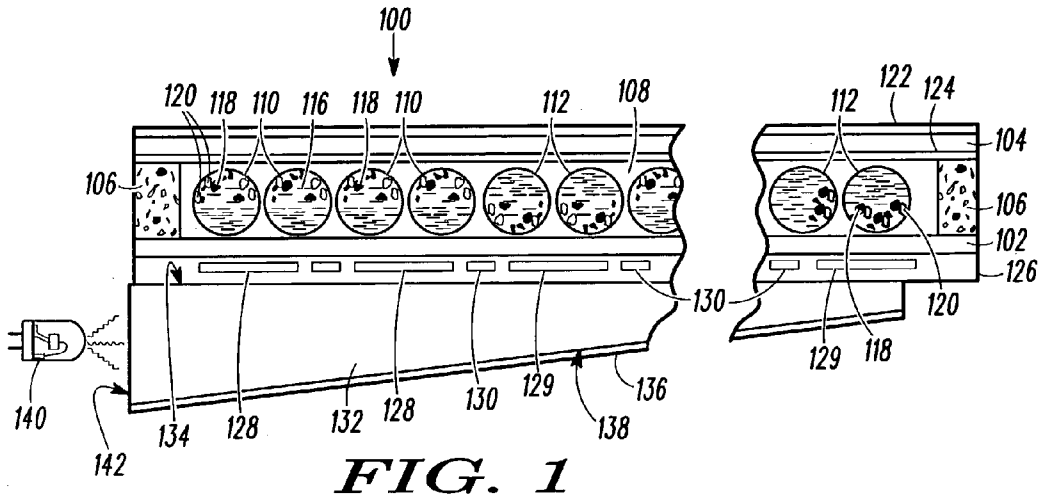

## PHOTOLUMINESCENT ELECTROPHORETIC DISPLAY

### BACKGROUND OF THE INVENTION

[0001] 1. Field of the Invention

[0002] The present invention relates in general to displays. More particularly, the present invention relates to electrophoretic displays.

[0003] 2. Description of Related Art

[0004] Proliferation of computers, and other electronic devices, such as for example advanced wireless telephones, personal digital assistants (PDA), electronic games, and new types of television monitors have increased the importance of display technologies.

[0005] Cathode Ray Tubes (CRT) and Liquid Crystal Displays (LCD) are the two most common types of displays. CRT displays are presently dominant. LCD displays have the advantage that they are essentially 'flat', having a small depth compared to the dimensions of the viewable area. The flatness of LCD displays compared to traditional CRT displays makes them especially suitable for use in small size portable devices, such as notebook computers, PDAs, and wireless telephones, and is also attractive for larger home entertainment, and commercial displays.

[0006] Flatness is a generally regarded as a positive attribute in display technology, and there are other types of displays, aside from LCD displays, that are flat. One other type of flat display technology is electrophoretic. Electrophoretic displays comprise a suspension of particles in a liquid. The suspension is held between two flat walls, one of which is transparent and serves as a viewable display surface. Optionally the suspension is encapsulated in many small capsules that are held between the two flat walls, or emulsified in a polymeric matrix. The particles have optical properties that are different from the liquid in which they are suspended. For example electrophoretic displays in which the particles are more reflective of light than the liquid have been proposed and electrophoretic displays in which the particles are luminescent have also been proposed. Each type is suited to use under particular ambient light conditions. Due to the electrochemical properties of the particles, and of the liquid, the particles spontaneously acquire a net charge when placed in the liquid. Having a charge, the particles can be caused to translate by an externally applied electric field. Electrodes are provided for imagewise application of electric fields to the suspension. Selectively causing the particles to translate to the viewable display surface, according to an image pattern, causes an image to appear at the viewable display surface. In as much as electrophoretic displays work by application of electric fields, they are potentially very efficient in terms of current consumption, which is a significant attribute for battery operated portable electronic devices.

[0007] Certain display applications, such as portable electronic devices, typically require that a display be able to operate in a wide range of ambient light conditions, i.e., in conditions ranging from mid day sun, to complete darkness.

[0008] It would be desirable to have an electrophoretic display that is capable of operating in wide range of ambient light conditions.

### BRIEF DESCRIPTION OF THE FIGURES

[0009] The present invention will be described by way of exemplary embodiments, but not limitations, illustrated in the accompanying drawings in which like references denote similar elements, and in which:

[0010] **FIG. 1** is a sectional elevation view of an electrophoretic display according to the preferred embodiment of the invention;

[0011] **FIG. 2** is a cross section of a photoluminescent particle used in the display according to an alternative embodiment of the invention;

[0012] **FIG. 3** is a flow chart of a method of forming an image according to the preferred embodiment of the invention; and

[0013] **FIG. 4** is a sectional elevation view of an electrophoretic display according to an alternative embodiment of the invention.

### DETAILED DESCRIPTION OF THE PREFERRED EMBODIMENTS

[0014] As required, detailed embodiments of the present invention are disclosed herein; however, it is to be understood that the disclosed embodiments are merely exemplary of the invention, which can be embodied in various forms. Therefore, specific structural and functional details disclosed herein are not to be interpreted as limiting, but merely as a basis for the claims and as a representative basis for teaching one skilled in the art to variously employ the present invention in virtually any appropriately detailed structure. Further, the terms and phrases used herein are not intended to be limiting; but rather, to provide an understandable description of the invention.

[0015] **FIG. 1** is a sectional elevation view of an electrophoretic display **100** according to the preferred embodiment of the invention. The electrophoretic display **100** comprises a back wall **102**, and a light transmissive front wall **104** that is spaced from the back wall **102**. A sealant **106** bonds, and seals the perimeters of the walls **102**, **104** forming a chamber **108** between the walls **102**, **104**.

[0016] A plurality of capsules **110**, **112** are located in the chamber **108**. Each of the capsules **110**, **112**, encloses a liquid **116**, a first plurality of reflective particles **118** that are reflective of at least a portion of the visible spectrum, and are preferably white i.e., reflective across the visible spectrum, and a second plurality of photoluminescent particles **120**. The particles **118**, **120** are suspended in the liquid **116**. The photoluminescent particles **120** preferably comprise phosphors. The reflective particles **118** and the photoluminescent particles **120** are characterized by electrophoretic mobility of the same sign, so that under the influence of a given field, the reflective particles **118**, and the photoluminescent particles **120** move in the same general direction. The liquid **116** is transmissive of radiation capable of exciting photoluminescence of the photoluminescent particles **120**, and preferably blocks light that is emitted by the photoluminescent particles **120**. The liquid **116** preferably absorbs visible light. The liquid **116** preferably comprises a nigrosin solution. Alternatively, instead of using capsules **110**, **112**, the liquid **116**, and particles **118**, **120** are emulsified in a polymeric matrix.

[0017] The back wall 102 is transmissive of at least radiation capable of exciting the photoluminescent particles 120, and the front wall 104 is transmissive of at least a portion of a spectrum emitted by the photoluminescent particles 120. The front wall is also transmissive of at least a portion of a spectrum reflected by the reflective particles 118.

[0018] An optical filter layer 122 is supported on the front wall 104. The optical filter is transmissive of at least a portion of the visible spectrum. In particular, the optical filter layer 122 is transmissive of at least a portion of the spectrum emitted by the photoluminescent particles 120, and at least a portion of the spectrum reflected by the reflective particles 118. The optical filter layer 122 blocks (either by reflection or absorption) radiation capable of exciting the photoluminescent particles 120. Alternatively, the optical filter 122 is eliminated and a front wall 104 is made from a material that has the optical properties of the optical filter layer 122. Alternatively, optical filter 122 is eliminated and the front wall made of a material that is transmissive of optical radiation capable of exciting the photoluminescent particles 120.

[0019] A transparent ground plane layer 124 is also supported on the front wall 104, opposite the optical filter 122, facing chamber 108. The transparent ground plane layer 124 is transmissive of at least a portion of the spectrum emitted by the photoluminescent particles 120 and at least a portion of the spectrum reflected by the reflective particles 118. The transparent ground plane layer 124 can for example comprise indium tin oxide (ITO), or a conductive transparent polymer such as poly (3,4) ethylenedioxythiophene/polystyrenesulfone acid (PEDOT/PSS) sold under the trade name ORGACON™ by Agfa of Ridgefield Park, N.J. Alternatively, the functions of the transparent ground plane layer 124, and the optical filter layer 122 are combined in a single layer. The relative positions of the transparent ground plane layer 124, the optical filter layer 122, and the front wall 104 are alternatively altered from what is shown in FIG. 1.

[0020] An active matrix 126 is supported on the back wall 102 opposite the chamber 108. Alternatively, the active matrix 126 is supported on the back wall 102 facing the chamber 108. The active matrix 126 comprises a rectangular array of pixel electrodes 128, 129 row conductors 130, column conductors (not shown), and thin film transistors (not shown). By application of signals to the individual row conductors 130, and individual column conductors voltages on the pixel electrodes 128, 129 (relative to the transparent ground plane layer 124) are controlled. The pixel electrodes 128, 129 are transmissive of radiation capable of exciting photoluminescence of the photoluminescent particles 120. The pixel electrodes 128, 129 preferably comprise ITO or PEDOT/PSS.

[0021] An optical coupling element 132 in the form of a wedge of transmissive material is located at the back of the electrophoretic display 100. An output surface 134 of the optical coupling element 132 abuts the active matrix 126. In the alternative case that the active matrix faces the chamber 108, the output surface 134 abuts the back wall 102. A reflective layer 136 is located on a canted surface 138 of the optical coupling element 132 that is opposite the output surface 134. One or more sources of radiation 140 (one shown) capable of exciting photoluminescence of the pho-

toluminescent particles 120 faces an input surface 142 of the optical coupling element 132. The source of radiation 140 preferably comprises an ultraviolet emitting diode that emits radiation including radiation in the range of 370 to 405 nanometers. Ultraviolet emitting diodes are efficient low power sources of ultraviolet radiation. Radiation emitted by the source of radiation 140 transmits through the input surface 142, is reflected by the canted surface 138, and propagates through the output surface 134, through the pixel electrodes 128, 129 through the back wall 102, through the liquid 116 to the photoluminescent particles 120. Thus, the photoluminescent particles 120 are optically coupled to the source of radiation 142 through the pixel electrodes 128, 129 which are transmissive of radiation capable of exciting photoluminescence of the photoluminescent particles 120. Alternatively, other types of optical coupling elements or more elaborate optical coupling arrangements that include multiple optical coupling elements are used in lieu of the optical coupling element 132 shown in FIG. 1.

[0022] The photoluminescent particles 120 preferably comprise a phosphor that is efficiently excited by radiation that is efficiently produced by a diode. In particular, the photoluminescent particles 120 preferably comprise one or more of the following phosphors:  $(\text{Ba}_{1-x-y-z}, \text{Ca}_x, \text{Sr}_y, \text{Eu}_z)_2 (\text{Mg}_{1-w}, \text{Zn}_w)\text{Si}_2 \text{O}_7$ , where  $X+Y+Z=1$ ,  $Z>0$ ; and  $0.05 \leq W \leq 0.50$ ;  $(\text{Sr}_x, \text{Ba}_y, \text{Ca}_z)_5 (\text{PO}_4)_3 \text{Cl:Eu}^{2+}$  where  $X+Y+Z=1$ ; and/or  $\text{Y}_2 \text{O}_3 \text{:Eu}^{3+}, \text{Bi}^{3+}$ . The foregoing phosphors are excited efficiently by radiation in the range of 370 to 405 nanometers which can be efficiently produced by diodes such as ultraviolet diode 140.

[0023] The optical filter layer 122 protects users from radiation emitted by the ultraviolet diode 140. The optical filter layer 122 also serves to shield the photoluminescent particles 120 from solar ultraviolet radiation.

[0024] In operation, ultraviolet diode 140 is powered causing the ultraviolet diode 140 to emit radiation that impinges on the photoluminescent particles 120, causing the photoluminescent particles 120 to emit visible light. Optionally the ultraviolet diode is powered, in response to a signal from a photodetector (not shown), only under low ambient light conditions. Electrical signals are applied to the row conductors 130 and column conductors (not shown) in order to selectively apply potentials to the pixel electrodes 128, 129 in order to cause the reflective 118, and photoluminescent 120 particles to move toward or away from the front wall 104.

[0025] At least two extreme states are useful in displaying information with the display 100. In a first state corresponding to a first group of capsules 110, and pixel electrodes 128 in FIG. 1, the reflective particles 118, and the photoluminescent particles 120 are located at the front wall 104. In the first state ambient light that is transmitted through the front wall 104 is reflected by the reflective particles 118 back through the front wall 104. Also, in the first state the photoluminescent particles 120 photoluminesce and emit visible light which is transmitted through the front wall 104.

[0026] In a second state corresponding to a second group of capsules 112 and pixel electrodes 129 in FIG. 1, the reflective particles 118, and the photoluminescent particles 120 are located near the back wall 102. In the second state ambient light transmitted through the front wall 104 will be absorbed by the liquid 116, and consequently will not be

reflected by the reflective particles **118**. Also, in the second state light emitted by the photoluminescent particles **120** will be absorbed by the liquid **116** and will not be transmitted through the front wall **104**.

[0027] By controlling the voltages applied to the pixel electrodes **128129** according to image information, images are caused to appear on the display **100** which is viewed by looking toward the front wall **104**. Having reflective particles **118**, and photoluminescent particles **120** that move in the same direction in response to applied fields allows the display **100** to display information under high ambient light conditions, in total darkness and under intermediate ambient light conditions. In conditions of lower intensity ambient light, photoluminescence of the photoluminescent particles **120** makes a dominant contribution to displaying of information, and in high ambient light conditions, the reflective particles **118** make a dominant contribution to displaying image information. The display **100** is operable under a wide range of ambient light conditions, and does not require drive signals applied to the pixel electrodes **128, 129** to be changed according to the ambient light conditions. The display **100** does not suffer from contrast reversal when operated under different lighting conditions.

[0028] Preferably, the ratio by surface area of the reflective particles **118** to the photoluminescent particles **120** is at least one-to-one.

[0029] The display **100** is alternatively made into a color display by adding color filters adjacent the front wall **104**, and driving the pixel electrodes **128, 129** according to color image signals. Alternatively, the display **100** is made into a color display by locating reflective particles **118** that reflect different colors (e.g., red, blue and green), and photoluminescent particles **120** that emit different colors over specific pixel electrodes **128, 129**.

[0030] FIG. 2 is a cross section of a photoluminescent particle **200** used in the display **100** according to an alternative embodiment of the invention. The photoluminescent particle **200** comprises a core **202**, and a coating of photoluminescent material **204** on the core **202**. In this embodiment the core **202** preferably comprises the same material e.g., titanium oxide, that is included in reflective particles, e.g., **118** with which the photoluminescent particle **200** is used.

[0031] FIG. 3 is a flow chart of a method **300** of forming an image according to the preferred embodiment of the invention. In step **302** a liquid suspension of reflective particles e.g., **118** and photoluminescent particles e.g., **120** having electrophoretic mobility of the same sign is irradiated with radiation capable of exciting photoluminescence of the photoluminescent particles e.g., **120**. The liquid of the suspension irradiated in step **302** is preferably transmissive of the radiation with which the suspension is irradiated, and preferably blocks light emitted by the photoluminescent particles e.g., **120**, and light that the reflective particles e.g., **118** can reflect. In step **304** electrical fields having directions as a function of position that are determined by image information are applied to the suspension irradiated in step **302**. Although shown in sequence, steps **302**, and **304** preferably occur concurrently.

[0032] FIG. 4 is a sectional elevation view of an electrophoretic display **400** according to an alternative embodiment

of the invention. The electrophoretic display **400** comprises a top wall **402**, and a bottom wall **404** that are bonded near their peripheries by a sealant **406** forming a chamber **408**.

[0033] A first plurality of capsules of a first type **414**, and a second plurality of capsules of a second type **416** are located in the chamber **408**. The capsules of the first type **414** enclose a first type fluid **418** in which a plurality of reflective particles **420** are suspended. The capsules of the second type **416** enclose a second type fluid **426** in which a plurality of photoluminescent particles **422** are suspended. The reflective particles **420** and the photoluminescent particles **422** are characterized by electrophoretic mobility of the same sign. Using separate capsules **414, 416** enclosing the different type fluids **418, 426** allows the fluids **418, 426** to be optimized (e.g., optically, as to specific gravity, and electrochemically) for each type of particle **420, 422**.

[0034] A plurality of parallel elongated row electrodes **410** (only one of which is visible in FIG. 4) are formed on the top wall **402** facing the chamber **408**. Similarly, a plurality of parallel elongated column electrodes **412** are formed on the bottom wall **404** facing the chamber **408**. The row electrodes **410** extend to an edge portion **424** of the top wall **402** where a connection is made to an external driver circuit (not shown). A similar extension of bottom wall (out of the plane of FIG. 4) is provided.

[0035] Pixel areas are defined by the overlap of crossing row electrodes **410**, and column electrodes **412**. The row electrodes **410** and the column electrodes **412** are conductive. The row electrodes **410** and the column electrodes **412** are used to apply electric fields to the pixel areas in order to induce electrophoresis of the reflective **420**, and photoluminescent particles **422** within the first type **418**, and second type **426** fluids respectively. Although as shown in FIG. 4 the size of the capsules **414, 416** is such that about two capsule diameters span the width of each of the column electrodes **412**, the capsules **414, 416** are preferably substantially smaller than the widths of the row **410**, column electrodes **412**, so that in the case of a random mix of capsules of the first **414**, and second **416** types there will be approximately proportionate numbers of capsules of both types in each pixel area. The scale of the capsules **414, 416** shown in FIG. 4 is used in the interest of clearly illustrating the capsules **414, 416** their contents.

[0036] An ultraviolet electroluminescent lamp **428** is located adjacent the back wall **404**, opposite the chamber **408**. The ultraviolet lamp **428** emits radiation that is capable of exciting photoluminescence of the photoluminescent particles **422**. The ultraviolet electroluminescent lamp **428** offers the advantage, especially for use in the electrophoretic display **400**, of flatness.

[0037] An optical filter layer **430** is located on the front wall **402** opposite the chamber **408**. The optical filter layer **430** serves a function analogous to the optical filter layer **122** shown in FIG. 1.

[0038] The column electrodes **412** and the second type fluid **426** is transmissive of radiation capable of exciting photoluminescence of the photoluminescent particles **422**. The first type fluid **418** absorbs light that the reflective particles **420** are capable of reflecting. The second type fluid **426** absorbs light emitted by the photoluminescent particles **422**. The row electrodes **410** are transmissive of at least a

portion of the spectrum emitted by the photoluminescent particles 422, and at least a portion of the spectrum reflected by the reflective particles 420.

[0039] An active matrix driving scheme is illustrated in FIG. 1, and a passive matrix driving scheme (using row 410, and column 412 electrodes) is illustrated in FIG. 4. Alternatively, a direct drive driving scheme is used. A direct drive driving scheme is especially suitable for activating predetermined pattern indicia, such as for example a seven segment display and/or a display including predetermined graphical icons. A direct drive display preferably includes one or more electrodes shaped according to indicia to be displayed.

[0040] Alternatively, in lieu of the reflective particles 118, shown in FIG. 1, and the reflective particles 420, shown in FIG. 4, smaller capsules that enclose reflective particles and move within the capsules 110, 112 shown in FIG. 1 or the capsules 414 shown in FIG. 4 are used. Also alternatively, in lieu of the photoluminescent particles 120 shown in FIG. 1, and the photoluminescent particles 422 shown in FIG. 4, smaller capsules that enclose photoluminescent particles, or photoluminescent dye, and move within the capsules 110, 112 shown in FIG. 1, or the capsules 414, 416 shown in FIG. 4 are used. Particles or such aforementioned smaller capsules are cohesive bodies. Such cohesive bodies are cohesive in as much as they are chemically, and physically stable in a liquid in which they are suspended, which implies that they do not break down. Whether particle or small capsule, in any particular embodiment the reflective cohesive bodies, and the photoluminescent cohesive bodies are characterized by electrophoretic mobility of the same sign.

[0041] According to another alternative particles, rather than using separate reflective and photoluminescent particles, cohesive bodies that comprise phosphor particles that are both photoluminescent and reflective are used. For example particles such as shown in FIG. 2 that are both photoluminescent and reflective can be used.

[0042] While the preferred and other embodiments of the invention have been illustrated and described, it will be clear that the invention is not so limited. Numerous modifications, changes, variations, substitutions, and equivalents will occur to those of ordinary skill in the art without departing from the spirit and scope of the present invention as defined by the following claims.

What is claimed is:

1. An electrophoretic display comprising:
  - a first wall; and
  - a second light transmissive wall spaced from the first wall;
  - one or more bodies of liquid located between the first wall and the second wall;
  - a plurality of first cohesive bodies that are light reflective and are characterized by electrophoretic mobility of a particular sign suspended in at least a subset of the one or more bodies of liquid;
  - a plurality of second cohesive bodies that are photoluminescent and are characterized by electrophoretic mobility of the particular sign suspended in at least a subset of the one or more bodies of liquid;

one or more electrodes located proximate the one or more bodies of liquid for imagewise application of electric fields to the one or more bodies of liquid; and

a source of radiation capable of exciting photoluminescence of the plurality of second cohesive bodies optically coupled to the plurality of second cohesive bodies.

2. The electrophoretic display according to claim 1 wherein:

the plurality of second cohesive bodies comprise particles that are coated with phosphor material.

3. The electrophoretic display according to claim 1 wherein:

a ratio of the surface area of the plurality of first cohesive bodies to the surface area of the plurality of second cohesive bodies is at least one to one.

4. The electrophoretic display according to claim 1 wherein:

the source of radiation comprises an electroluminescent lamp.

5. The electrophoretic display according to claim 1 wherein:

the liquid is transmissive of radiation capable of exciting photoluminescence of the second cohesive bodies, and blocks radiation emitted by photoluminescence of the second cohesive bodies.

6. The electrophoretic display according to claim 5 wherein:

the liquid comprises nigrosin.

7. The electrophoretic display according to claim 1 wherein:

the one or more electrodes comprise an array of electrodes that are transmissive of radiation capable of exciting photoluminescence of the second cohesive bodies; and

the source of radiation is optically coupled to the second plurality of cohesive bodies through the array of electrodes.

8. The electrophoretic display according to claim 7 wherein:

the array of electrodes comprise indium tin oxide.

9. The electrophoretic display according to claim 7 wherein:

the array of electrodes comprises a transparent conductive polymer.

10. The electrophoretic display according to claim 7 wherein:

the source of radiation comprises an emitting diode that emits radiation in the range of 370 to 405 nanometers; and the second cohesive bodies comprise one or more phosphors selected from the group consisting of:

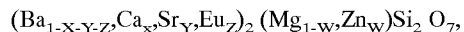

wherein

$$X+Y+Z \leq 1;$$

$$Z > 0; \text{ and}$$

$$0.05 \leq W \leq 0.50;$$

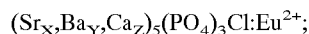

wherein:

$X+Y+Z=1$ ; and

$Y_2 O_3:Eu^{3+},Bi^{3+}$ .

**11.** The electrophoretic display according to claim 7 further wherein:

the array of electrodes is located proximate the first wall; and

the electrophoretic display further comprises:

an optical filter layer that transmits light in the visible portion of the spectrum; and blocks radiation capable of exciting photoluminescence of the second cohesive bodies said optical filter layer located proximate the second light transmissive wall.

**12.** A method of forming an image comprising:

irradiating a suspension in one or more bodies of liquid of reflective cohesive bodies, and photoluminescent cohesive bodies characterized by electrophoretic mobility of the same sign with radiation capable of exciting photoluminescence of the photoluminescent cohesive bodies; and

applying electric fields having directions as a function of position determined by image information to the suspension.

**13.** An electrophoretic display comprising:

a first wall; and

a second light transmissive wall spaced from the first wall;

one or more bodies of liquid located between the first wall and the second wall;

a plurality of visible light reflecting, photoluminescent cohesive bodies suspended in the one or more bodies of liquid, said reflecting, photoluminescent cohesive bodies comprising reflective phosphor particles;

one or more electrodes located proximate the one or more bodies of liquid for imagewise application of electric fields to the one or more bodies of liquid; and

a source of radiation capable of exciting photoluminescence of the plurality of visible light reflecting, photoluminescent cohesive bodies optically coupled to the plurality of visible light reflecting, photoluminescent cohesive bodies.

**14.** The electrophoretic display according to claim 13 wherein:

the source of radiation comprises an ultraviolet emitting diode.

**15.** The electrophoretic display according to claim 13 wherein:

the source of radiation comprises an electroluminescent lamp.

**16.** The electrophoretic display according to claim 13 further comprising:

an optical filter layer that transmits light in the visible portion of the spectrum; and blocks radiation capable of exciting photoluminescence of the light reflecting, photoluminescent cohesive bodies said optical filter layer located proximate the second light transmissive wall.

**17.** The electrophoretic display according to claim 1 wherein:

the plurality of visible light reflecting, photoluminescent cohesive bodies comprise particles that are coated with phosphor material.

**18.** The electrophoretic display according to claim 13 wherein:

the liquid is transmissive of radiation capable of exciting photoluminescence of the light reflecting, photoluminescent cohesive bodies, and blocks radiation emitted by photoluminescence of the light reflecting, photoluminescent cohesive bodies.

**19.** The electrophoretic display according to claim 18 wherein:

the liquid comprises nigrosin.

**20.** The electrophoretic display according to claim 13 wherein:

the one or more electrodes comprise an array of electrodes that are transmissive of radiation capable of exciting photoluminescence of the light reflecting, photoluminescent cohesive bodies; and

the source of radiation is optically coupled to the light reflecting, photoluminescent cohesive bodies through the array of electrodes.

**21.** The electrophoretic display according to claim 20 wherein:

the array of electrodes comprise indium tin oxide.

**22.** The electrophoretic display according to claim 20 wherein:

the array of electrodes comprises a transparent conductive polymer.

\* \* \* \* \*